

## TECHNICAL DATA SHEET

### CERAMIC BLADE NO. 60099C



CERAMIC BLADE NO 60099C is a very high-quality blade made of ceramic. It remains very sharp for a very long time and has two cutting edges that can be used one after the other for an even longer service life. The deep edge makes cutting easier and the rounded tips increase user safety. The blade is 55.5 mm long, 19 mm wide and 0.65 mm thick.

CERAMIC BLADE NO. 60099C is available under order number 1760099.25 as 2 on a self-service card.

#### PRODUCT DETAILS

<b>Order No.</b>	NO. 1760099.25
<b>Blade size (L x W)</b>	55.5 x 19 mm
<b>Material thickness</b>	0.65 mm
<b>Weight Blade</b>	2.6 g
<b>Basic material</b>	Ceramic
<b>Refinement/ Version</b>	stainless and acid resistant
<b>Ground</b>	deep-edged, 2-sided ground-edge
<b>Blade facets</b>	Double bevel edge-ground
<b>Safety feature</b>	rounded blade tips
<b>Blade characteristics</b>	2-cutting edge blade

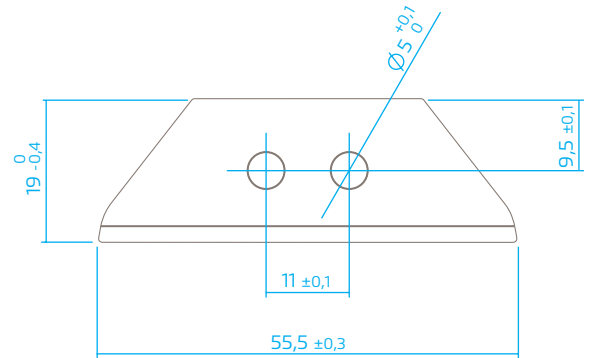



#### PACKAGING DETAILS

<b>Packaging unit (PU)</b>	2 on self-service card
<b>Size PU</b>	84.5 x 5 x 160.0 mm
<b>Weight PU</b>	22.0 g
<b>EAN Code PU</b>	4002632801730
<b>Customs tariff number</b>	69149000



#### PRODUCT FEATURES

##### Technical features

 Rounded-tip trapezoid blade	 2-sided ground-edge	 deep-edged	 2-cutting edge blade
 Ceramic	 Non-magnetic	 Non-conductive	 Chemically inert
 Non-oiled	 Non-rusting		

The blade can be used in the following MARTOR knives: SECUPRO MAXISAFE, SECUPRO MEGASAFE, SECUNORM 525.

## SAFETY ADVICE

---



**CAUTION: The blade is sharp and can result in serious and deep cuts. Therefore, never reach into the blade!**

Only use cutting tools that are in perfect condition with sharp, clean and undamaged MARTOR blades. Also make sure that the knife's operation is not impaired by the material to be cut or by dirt or particle deposits around the blade.

**1. Replacement of spare parts:** Replace any blades that become dull at the right time! Dispose of old blades in a proper fashion. They should not be placed in a waste paper bin, as this poses a considerable danger of injuries.

**2. Non-use of the knife:** Always secure the blade in such a way (depending on product type) that injuries due to cuts are excluded. Store the knife in a secure place.

**3. Care instructions:** To guarantee a long service life, always keep the knife clean and do not expose it to unnecessary soiling and humidity.

**CAUTION: No liability will be assumed for consequential losses. Subject to technical changes and errors! This knife does not belong in the hands of children!**

## CONTACT

---

MARTOR KG | Lindgesfeld 28 | 42653 Solingen | Germany  
T +49 212 73870-0 | info@martor.de | www.martor.com